

# How Technology Can Help with Social Distancing Requirements

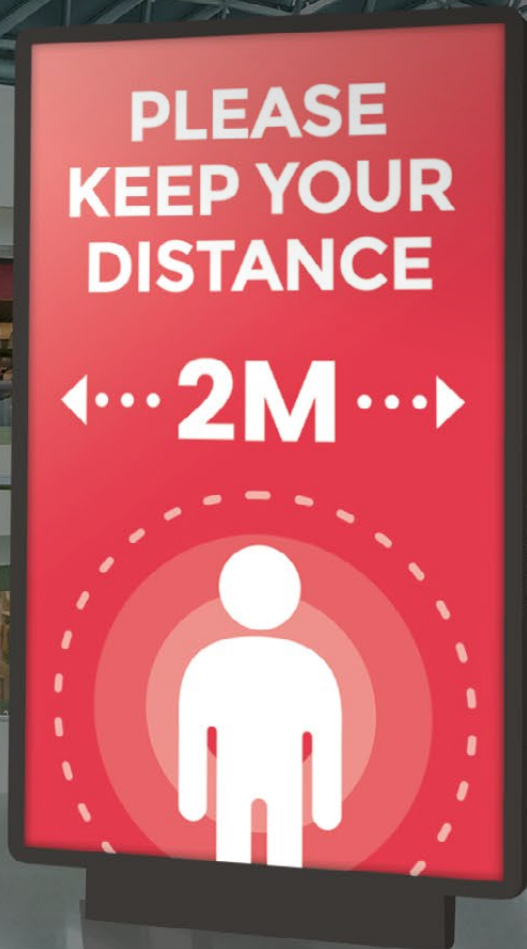

# Introduction

With social distancing becoming the norm for most of us in our daily lives, businesses and organisations are looking to technology solutions to help them adapt their working practices.

Many businesses have been hit financially by the Covid-19 outbreak and, now with the lockdown easing, are looking for ways to reboot their operations - whilst safely implementing the new guidelines.

Likewise, educational institutions, workplaces and the transport sector, are all keen to get back to some sort of normality, whilst protecting the safety of their students, staff and customers.

In this guide we will outline technology solutions available through Square One that can aid with social distancing requirements.

If you would like more information on any of the products or solutions featured, please contact our **sales team on 01 274 3070**

## Innovative Solutions from:

 **ClickShare**  **BOSCH** **BrightSign**

**HIKVISION**  **LG** **NEC** **OKI**

**Panasonic**  **SAMSUNG TAURI**  
BUSINESS Professional Display Solutions

and many more...

## Contents

Helping Retail Stores..... 4

Helping Workplaces..... 6

Helping the  
Transport Sector..... 8

Helping  
Universities..... 10

Solutions from  
BrightSign ..... 12

Solutions from LG..... 13

Solutions  
from NEC..... 14

Solutions from OKI..... 15

Solutions from  
Philips & Bosch..... 16

Solutions from  
Samsung ..... 17

# Helping Retail Stores

**Now the ROI's lockdown is easing, more retail stores are keen to reopen, while also protecting shoppers and staff.**

As we have seen in essential stores, floor signage is now commonplace, as is digital signage promoting safe social distancing.

Like any crisis period in history, it is at this time technology innovations are accelerated. Many of our manufacturers have rapidly developed solutions and partnerships to help businesses reopen in the safest way possible.

[Explore our featured solutions on these pages to see how technology can help.](#)



## Digital signage screens to convey real-time public health messaging

Increasingly, retail stores have been utilising digital signage to ensure the public are informed of the latest safety measures as well as any adjustments to business service.

[Explore our featured digital signage portfolio by visiting pages 14, 15 & 17.](#)



## BrightSign solutions for touchless interactivity & social distancing

Keen to support retail businesses who want to reopen safely, BrightSign have developed a range of Covid-19 touchless solutions. These include a way to control an in-store interactive display using an individual's mobile phone.

[Find out more by visiting page 12.](#)



## Philips and Bosch PeopleCount safer social distancing solution

Combining Philips displays and Bosch's intelligent cameras, retail stores can track the number of customers entering and leaving a store, so real time capacity data can be displayed on the screens.

[Find out more about this innovative solution on page 16.](#)



## OKI printers for cost-effective floor sticker solutions

Answering the demand from retailers, OKI offer cost-effective in-house printers that can easily and cheaply print floor sticker media. Not only this, they are currently offering FREE media packs, so stores have the artwork ready to go.

[Find out more on page 15.](#)

For pricing or more information on any of the solutions featured, please contact our sales team on 01 274 3070.



# Helping Workplaces

As lockdown eases further, the ROI's workplaces are looking for ways to reopen their offices safely, even if it means having less staff on-site, and a proportion of workers still working from home.

With prolonged periods of working from home looking likely, many staff are now upgrading their home office equipment.

In addition to this, workplaces will be looking for solutions that help on-site workers stay safe, feel connected and promote effective hybrid-meetings.

Explore our featured solutions on these pages to see how technology can help.



## Tauri temperature-check tablets offer no-contact temperature scan

Contactless temperature screening at workplace entrances can help give employers and co-workers increased peace of mind that safety precautions are in place. These provide an alert when a person is running a high temperature and state that the individual should not enter the building.



## Upgrade home office set-ups with our working from home products

Many companies look set to continue offering home working, at least to a proportion of their staff, until the end of the year, if not beyond. Square One have a vast portfolio of monitors, webcams, printers, scanners, keyboards, mice, audio, screen mounts and more – to help these workers stay productive.



## Connecting on-site and remote workers with BYOM

Effective collaboration between on-site and remote workers has never been more important. Barco's ClickShare Conference products can ensure that not just Bring Your Own Device (BYOD) but Bring Your Own Meeting (BYOM), where staff seamlessly connect with the existing conferencing solution and hardware is easily possible.

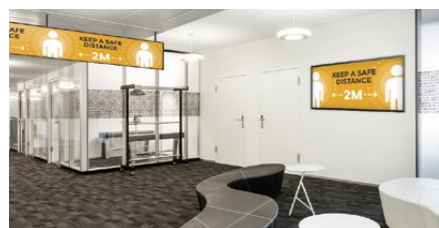

## Digital signage screens to convey real-time public health messaging

Digital displays in corporate offices can help display social distancing messaging to encourage compliance amongst workers. These eye-catching displays can also be used to convey motivational office information such as projects won and real-time call stats.

Explore our featured digital signage portfolio by visiting pages 14, 15 & 17.



## All-in-one LED screen for displaying remote workers in high definition

For corporate offices looking for a standout, highly visible display in their boardroom, the all-in-one Samsung 130" LED bundle can offer an ideal solution. Site survey, delivery, wall mount and installation are all included, allowing for a quick office upgrade.

Find out more on page 17.



## Future proof your signage network

With less personnel in the office, now is a great time to upgrade AV networks. AVoIP is established as the way forward for distributing high quality AV signals using standards-based protocols across IP networking infrastructure at any scale (unicast and multicast) and at significant cost advantages.

Talk to us about our AVoIP products and solutions.



For pricing or more information on any of the solutions featured, please contact our sales team on 01 274 3070.

# Helping the Transport Sector

With staff slowly returning to their workplaces and the retail and tourism sector moving towards gradually reopening - the transport sector needs to ensure social distancing measures are in place.

Not only that, they need to carefully monitor public areas for capacity numbers and safety announcements must be clearly seen and heard.

One of the hardest hit sectors, the airline industry, is having to ensure comprehensive safety measures such as temperature sensors are in place to help consumer confidence.

Explore our featured solutions on these pages to see how technology can help.



## Outdoor kiosk displays for route finding and social distancing messages

Digital signage has never been more important for the transport sector. Not only can it help with wayfinding, it can also be used to prompt social distancing. An ideal solution from Square One is a Samsung OH46F IP56 rated outdoor display housed in a Peerless KOP2546-OHF kiosk mount.



## Airports use digital signage screens to convey public health notices

Visual communication in airports is essential in encouraging safer behaviour and increasing passenger confidence. Screens can be used to show these notices, as well as real-time travel information.

Explore our featured digital signage portfolio by visiting pages 14, 15 & 17.



## NEC control room setups for surveillance and real-time capacity monitoring

With safe capacity management a high priority for the transport sector right now, it is likely that there will be an increased demand for control centers. NEC have a range of displays ideal for these scenarios alongside their highly acclaimed Hiperwall software control system.



## Public Address and Voice Alarms to convey auditory safety information

Audio is just as important for safety information as visual communications. The Bosch paging PLENA system can provide background music and all-important social distance reminders.

Contact our sales team for more information.

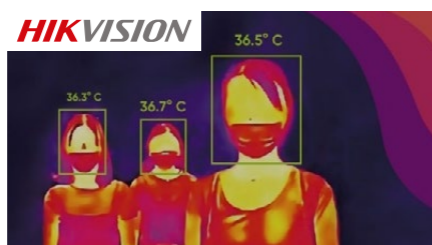

## Hikvision cameras enable passenger temperature sensing in airports

With advanced detectors and algorithms, Hikvision's Thermographic Cameras are designed to detect elevated skin-surface temperatures and can be used for rapid and preliminary temperature screening in public places.

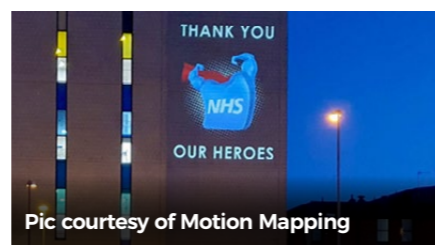

## Showing support through Projection Mapping

To showcase morale-boosting messaging and remind people why social distancing is important, there can be nothing better than a showstopping projection mapping display in a public space. We supply a range of high-end projectors that can make these a reality.



For pricing or more information on any of the solutions featured, please contact our sales team on 01 274 3070.

# Helping Universities

## Schools and universities are due to reopen in September for the 20/21 new school year.

However, many universities are gearing themselves up for a continuation of online lectures and classes for the autumn semester, if not even longer. And it is likely that if students do go back, strict social distancing measures will be in place, alongside smaller classes and 'blended' online and in-person learning.

Universities face a financial catastrophe if they cannot provide high quality online teaching and learning resources, so demand for professional video and streaming equipment in this sector has increased. Likewise, students will be looking to upgrade their home office equipment.

Explore our featured solutions on these pages to see how technology can help.



### Camera systems for distance learning

eLearning systems enable high quality lectures to be available to students remotely, live and on demand. Systems such as these require a professional PTZ camera to film a lecture in very high-quality HD or 4K.

For more info, check out our extensive range of cameras at [www.holdan.co.uk/ptz](http://www.holdan.co.uk/ptz)



### Lecture capture systems for live and on-demand streaming

Epiphan and Lumens lecture capture systems blend cameras, teaching materials and presentations. They deliver video-based learning resources for distance learning, self-initiated education and revision.

For more info, go to [www.holdan.co.uk/lecturecapture](http://www.holdan.co.uk/lecturecapture)



### Upgrade student set-ups with our studying from home products

Many universities look set to continue to deliver online lessons and classes, until the end of the year, if not beyond. Square One have a vast portfolio of monitors, webcams, printers, scanners, keyboards, mice, audio, screen mounts and more - to help these students stay connected.



### Digital signage for campus communications and social distancing prompts

Digital signage in universities has long been popular for wayfinding and student announcements. These screens can now also be used to promote social distancing prompts and real-time student safety information.



### All-in-one 138" Absen LED screen for university lobbies

With less students and staff on campus, now is a great time for AV installs. Universities can create an eye-catching first experience by installing an LED display in their lobby, ready for when students return. Site survey, delivery, wall mount and installation are all included, [contact avsales@squareone.ie](mailto:avsales@squareone.ie) for more info.



### Wireless collaboration

Bring your own meeting (BYOM) enables staff and students to connect with existing hardware using their own devices. Our wireless connectivity portfolio includes Barco, Mersive and Sony TEOS.

For pricing or more information on any of the solutions featured, please contact our sales team on 01 274 3070.



## Solutions for touchless interactivity and social distancing.

BrightSign are the market leaders in digital signage media players. Their new product family will help retail, higher ed, corporate, hospitality and more – open up for business in as safe a way as possible.



### BrightLink

- Delivers touchless interactivity with any digital sign by making a phone the remote controller
- Links any phone to your signage with a quick QR code scan - no app needed
- Provides an affordable & Internet-free solution using a BrightSign player with an installed wireless module & your custom content
- Uses proven BrightSign technology that can easily be deployed with confidence for new & existing installations

### BrightVoice™

- Gives a hands-free interactive experience with voice-activated digital signage
- Employs intelligent speech-to-text decoding to determine user intent & ensure accuracy
- Offers a tailor-made solution that runs in an offline environment for a controlled & reliable experience
- Deciphers voice commands without recording or storing them for a secure, anonymous solution

### BrightMenu

- Eliminate the risk of sharing menus by viewing it on your phone with a simple scan of a QR code
- Deliver your touchless menu to hundreds of connected phones at once
- Provide your menu content for simple viewing or make the phone your digital sign with an engaging interactive menu
- Does NOT require an internet connection, an app or even a display

### BlueFox Count + BrightSign

BlueFox's foot traffic analytics solution supports a wide range of BrightSign media players. BlueFox Count sends real-time alerts when a location surpasses its capacity and triggers signage to display "Please wait outside" messaging until it is safe to enter.

To find out more, contact our sales team on 01 274 3070

## Communication in times of need.

More than ever, relaying information to employees and customers is critical, especially when health protocol messages can change at any moment. With easy-to-use digital signage you can update messaging as often as necessary—even remotely from a central location.



### LG86BH5C and LG88BH7F Manage content remotely with SOC

- Ultrawide display - more than 2m width so can be used for dynamic social distancing messaging. What's easier to show a 2m message than a 2m display!
- SoC so can run signage without additional hardware
- Can be repurposed as portrait signage once pandemic is over



### LGLAA015FL7BUN1

- 130" large screen with no bezel
- Wall or floor mount options
- Easy installation options available



### LG49XS4F and PEERSR560M

- Indoor, high-brightness, window-facing digital signage
- Let customers know you are open, display limited to-go menus and pick-up instructions, offer words of encouragement, and more

## Uncompromising reliability, longevity and performance.

NEC's comprehensive and solution-oriented portfolio is unique in the AV market. The models below have been chosen for your customer's needs now, but that's not to forget about projection, monitors, interactive displays and dvLED.



### NECLCDC551 Best price for 24/7 operation

- Slim bezel and depth design
- 24/7 operation
- Low reflection level



- ### NECLCDV484
- Optional human sensor can change content based on audience proximity
  - 24/7 operation in portrait or landscape
  - High brightness level of 500cd/m<sup>2</sup>



### NECLCDC651Q Protective glass available

- Human Sensor can change content based on audience proximity
- UHD display with 24/7 operation
- Low reflection level

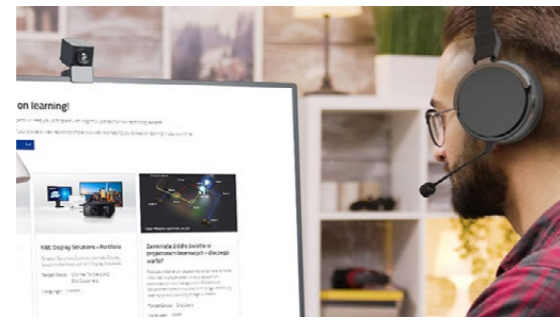

### NEC Webinars - Keep on learning!

NEC's series of free webinars on a wide range of subjects will keep you up to speed with insightful updates from our technology experts.

Register now to view the upcoming schedule or to access previous recordings. You only have to register once in order to have access to the webinar portal.

[Register](#)

## Floor stickers are the ideal solution for encouraging social distancing in stores.

The requirement to keep a safe distance away from others when out in public is now at the forefront of our minds. An essential journey to the nearest shop to stock up on food would likely involve you benefiting from the help of floor stickers. Some more homemade than others.



### PaperCutMF<sup>®</sup>

- Pair this with papercut software and you won't even have to touch the printer (other than to put paper in!)
- Papercut is print management software that helps millions of people around the globe to minimise waste while having a secure and easy printing experience.

Typically, floor stickers are used for directing customers around stores, displaying welcome messages at entrances and thank you messages at exits.

From getting the messaging of the floor sticker right, creating an effective design, choosing the right size and format, deciding on the best material for the application, sourcing and ordering media, testing and visualising in-store, printing and despatching the stickers to each location, the end-to-end process is time consuming.

Even if outsourced, businesses are reliant on external print suppliers' timelines. And for businesses who are committed to ensuring the safety and wellbeing of customers and staff during a pandemic, while getting their business fully operational, time is of the essence.

### Get started with an OKI bundle

- STEP 1** Purchase your OKI COVID-19 Signage Solution.
- STEP 2** Download the Free OKI Corporate Toolkit.
- STEP 3** Print and display your signage in minutes.



### Bundle Includes:

- C834dnw Printer
- Toner-Yellow 5k
- Toner-Magenta 5k
- Toner-Cyan 5k
- Toner Blk
- Floor circle media (Pack 100)
- Mini banner (pack 50)
- Floor Banner (pack 50)



## PeopleCount: Give your customers confidence with safer social distancing solutions from Philips and Bosch.

Whether for a retail environment, a cinema or any other public venue, maintaining safe social distance is a priority. Now, we're combining the strength of our partnerships with the power of our Android displays to bring timely, tested, safe social distancing solutions for public settings across Europe and beyond.

All designed to equip managers with the information they need to manage capacity effectively and efficiently, while keeping their customers informed and engaged. Moving them, and you, back into business confidently.

### Stand-alone people counting solution

Installation diagram:

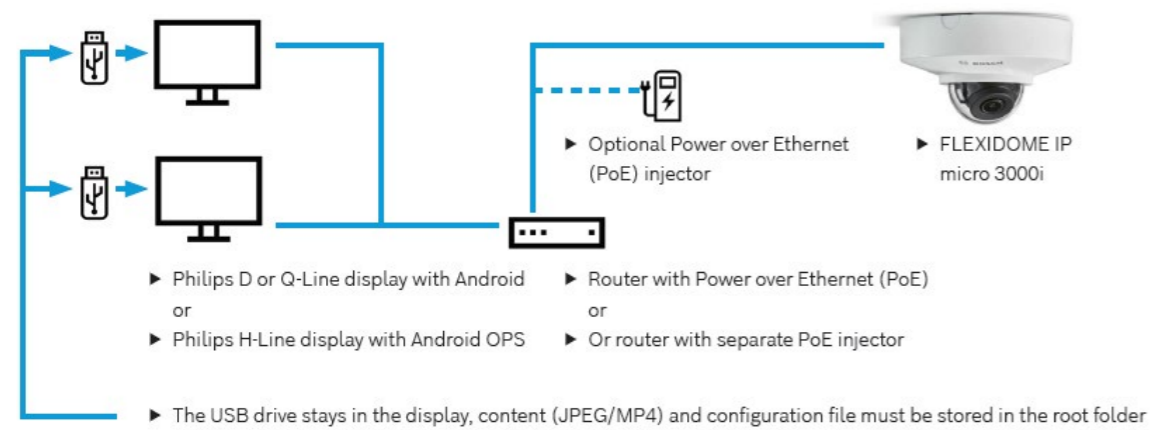

### Minimum required devices:

- One Bosch camera with Video Analytics
- One Philips D-Line, Q-Line or H-Line Display
- One Power over Ethernet (PoE) enabled router or a normal router and a PoE injector
- One USB drive (minimum 2GB)
- One bracket for the display (depending on installation scenario)
- APK and configuration files

### PeopleCount single entrance sensor and signage

- Tracking the number of customers entering and leaving a public setting through a single entrance.
- Delivering real-time information to one display for customer queue communications via a simple traffic light system.

### PeopleCount multi-entrance software, sensor and signage

- For settings with multiple entry points.
- Delivering powerful insights for effective capacity management and queue communications.
- An inclusive Digital Signage experience to enhance customer information at Point of Sale.

# SAMSUNG

By 2021, 77% of digital signage will be UHD\*

Future proofing your digital signage will solve challenges now and will continue to bring benefits in the future.

With visual display technology improving across devices, viewers have developed an ever-growing expectation for better picture quality. It's becoming increasingly important for businesses to have rich and vivid display capabilities. As UHD resolution continues to grow in popularity, it is essential for businesses to deliver superb picture quality for their customers.



### QBR series

- 13" to 98"
- 350 nit brightness
- 24/7 operation time
- SOC embedded making it perfect for signage applications



### QMR series

- 32" to 75"
- 500 nit brightness
- 24/7 operation time



### LED

Speak to our sales specialists to understand more about our LED offering on: [avsales@squareone.ie](mailto:avsales@squareone.ie)



### MagicINFO™

MagicINFO™ is a powerful content and device management solution giving businesses the ability to easily create, schedule and play content across a signage network. Users can analyse their data and automate promotions to reduce costs and grow their business.

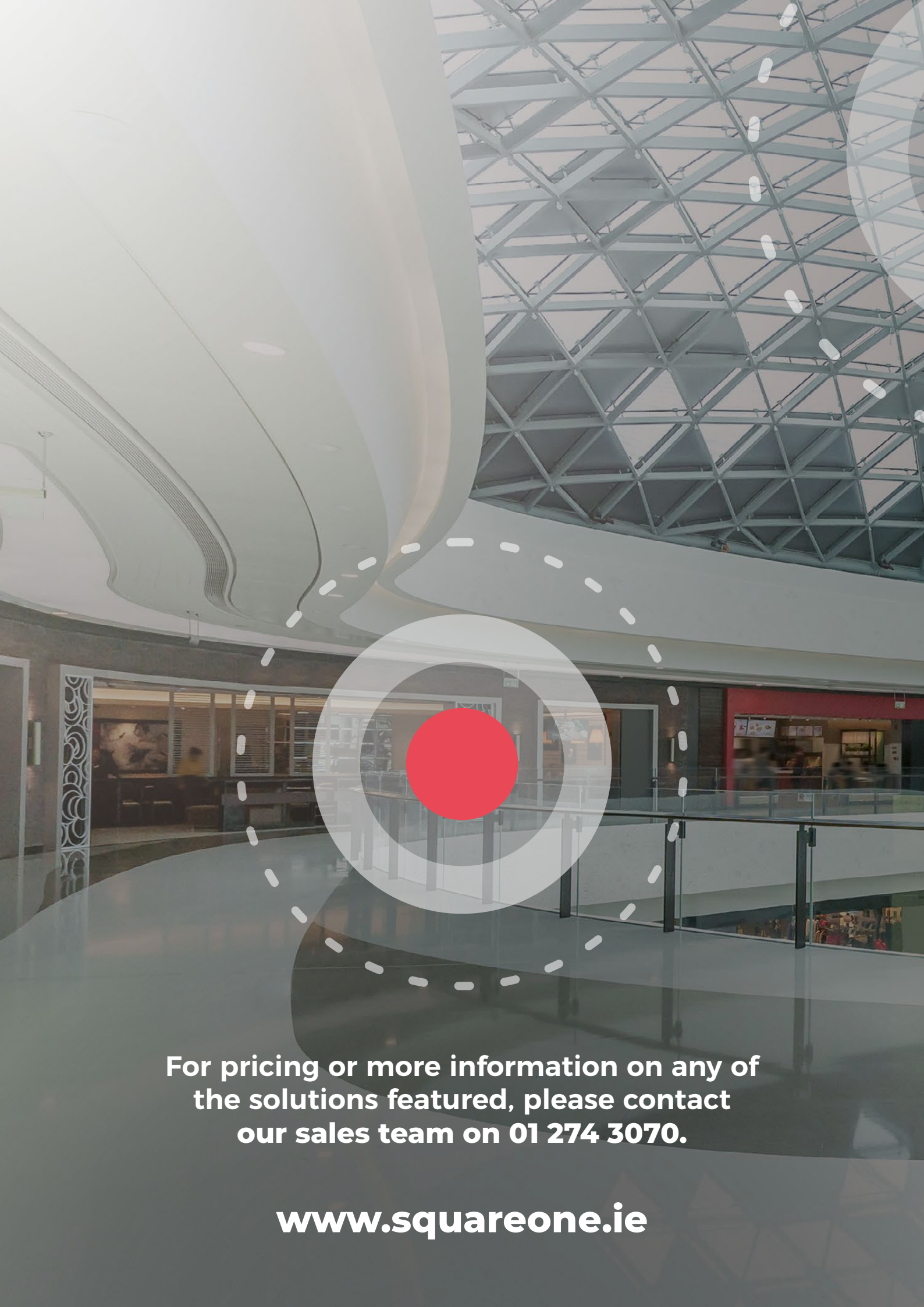

**For pricing or more information on any of  
the solutions featured, please contact  
our sales team on 01 274 3070.**

**[www.squareone.ie](http://www.squareone.ie)**